





# MID BAND

## 1710-2170MHz



## Overview

-  2 Ports / One horizontal lobe
-  Average gain: 22 dBi
-  1710MHz-2170MHz
-  Passive



RI 0302251-04



## RF Parameters

All clusters

Parameter Name	Unit	Value
Frequency Range	MHz	1710-2170
Polarization	°	+45 / -45
Electrical Downtilt	°	0,5
Impedance	Ω	50
Voltage Standing Wave Ratio		< 1,5:1
Passive Intermodulation	dBc	< -153
Return loss	dB	> 14
Inter-cluster Isolation	dB	> 21
Maximum Effective Power Per Port	W	500
Maximum Effective Power Per Cluster	W	2000

Parameter Name	Unit	Value
Cluster Name		1
Nominal Direction	°	0
Nominal Horizontal Half-Power Beamwidth	°	42
Port Number		1 / 2
Intra-cluster Isolation	dB	> 21
Frequency Sub Range	MHz	1710-2170
Gain	dBi	20 → 24
Azimuth Beamwidth	°	42
Elevation Beamwidth	°	3,1
Elevation Downtilt Deviation	dB	< 0,3
First Upper Sidelobe Suppression	dB	> 22
Upper Sidelobe Suppression Peak To 20°	dB	> 22
Upper Sidelobe Suppression Horizon To 20°	dB	> 22
Maximum Upper Sidelobe Suppression	dB	> 22
Null Fill	dB	> -30
Front To Back Ratio Total Power +/-30°	dB	> 25
Efficiency	dB	-0,09
Cross Polar Discrimination at Mechanical Boresight	dB	> 11

## Mechanical Parameters:

Parameter Name	Unit	Value
Connector Type		4.3-10 Female
Location		Back
Mechanical Boresight	°	0
Antenna dimensions H xW x D	mm	2494 x 359 x 270
Packing size H xW x D	mm	2 boxes: 2600 x 390 x 290
Weight without accessories	kg	36,5
Survival Wind Speed	km/h	250
Windload	N	Frontal: 945 Lateral: 572 Maximum 360: 1198
Software simulated results at 150km/h		
Radome Material		PC
Radome Color		RAL7038
Product environmental compliance (general)		ROHS
Product environmental compliance (conditions)		ETSI EN 300019-2-4, Class 4, 1E
Mechanical distance between antenna mounting points	mm	2500
Number of mounting points		2
Lighting protection		Yes

(considering the presence of a surge arrester lightning protection on RRH)

### Port external interface

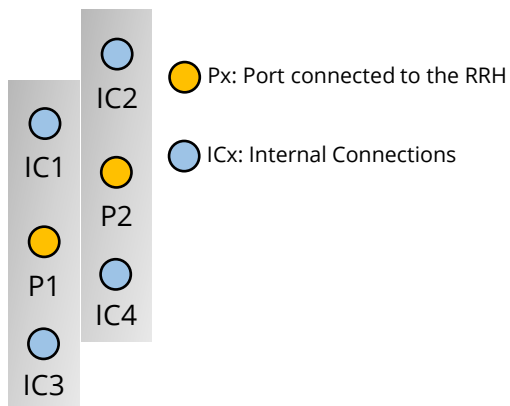

### Mounting

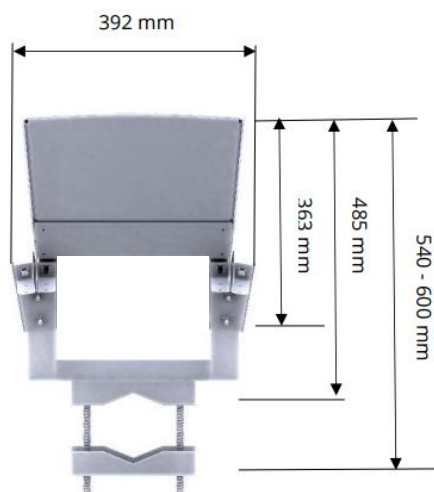

Bracket for tube Ø40-120mm  
Can be adapted upon request

### Beam configuration

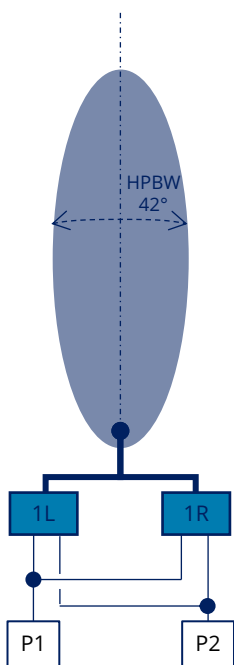



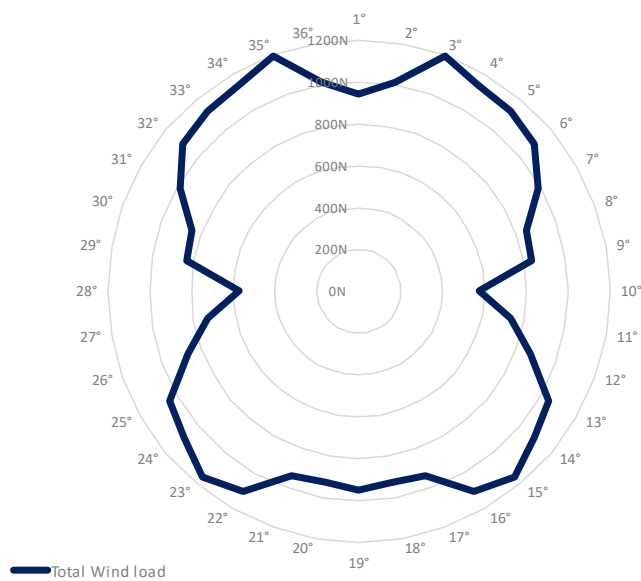

### Windload



RI 0301252-05  
 RURAL ANTENNA 1 beam x 42° x 25dBi MB

## Overview

-  2 Ports / One horizontal lobe
-  Average gain: 25 dBi
-  1710MHz-2170MHz
-  Passive

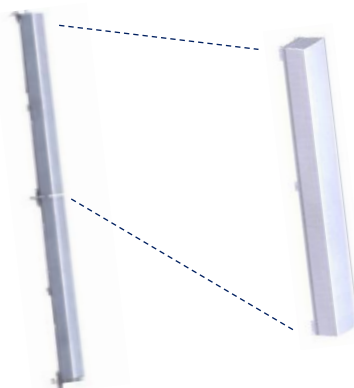
 RI 0302251-04  
**X 2**

All clusters

Parameter Name	Unit	Value
Frequency Range	MHz	1710-2170
Polarization	°	+45 / -45
Electrical Downtilt	°	0,5
Impedance	Ω	50
Voltage Standing Wave Ratio		< 1,5:1
Passive Intermodulation	dBc	< -153
Return loss	dB	> 14
Inter-cluster Isolation	dB	> 21
Maximum Effective Power Per Port	W	500
Maximum Effective Power Per Cluster	W	2000

Parameter Name	Unit	Value
Cluster Name		1
Nominal Direction	°	0
Nominal Horizontal Half-Power Beamwidth	°	42
Port Number		1 / 2
Intra-cluster Isolation	dB	> 21
Frequency Sub Range	MHz	1710-2170
Gain	dBi	23 → 27
Azimuth Beamwidth	°	42
Elevation Beamwidth	°	1,6
Elevation Downtilt Deviation	dB	< 0,3
First Upper Sidelobe Suppression	dB	> 11
Upper Sidelobe Suppression Peak To 20°	dB	> 11
Upper Sidelobe Suppression Horizon To 20°	dB	> 11
Maximum Upper Sidelobe Suppression	dB	> 11
Null Fill	dB	> -21
Front To Back Ratio Total Power +/-30°	dB	> 25
Efficiency	dB	-0,09
Cross Polar Discrimination at Mechanical Boresight	dB	> 11

## Mechanical Parameters:

Parameter Name	Unit	Value
Connector Type		4.3-10 Female
Location		Back
Mechanical Boresight	°	0
Antenna dimensions H xW x D	mm	4988 x 359 x 270
Packing size H xW x D	mm	3 boxes: 2600 x 390 x 290
Weight without accessories	kg	91
Survival Wind Speed	km/h	250
Windload	N	Frontal: 1906 Lateral: 1550 Maximum 360: 2541
Software simulated results at 150km/h		
Radome Material		PC
Radome Color		RAL7038
Product environmental compliance (general)		ROHS
Product environmental compliance (conditions)		ETSI EN 300019-2-4, Class 4, 1E
Mechanical distance between antenna mounting points	mm	2500
Number of mounting points		3
Lighting protection		Yes

(considering the presence of a surge arrester lightning protection on RRH)

### Port external interface

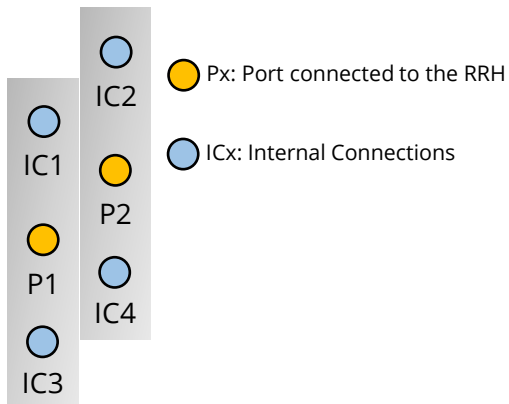

### Mounting

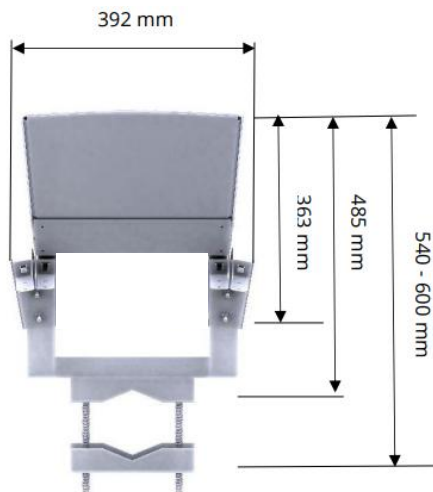

Bracket for tube Ø40-120mm  
Can be adapted upon request



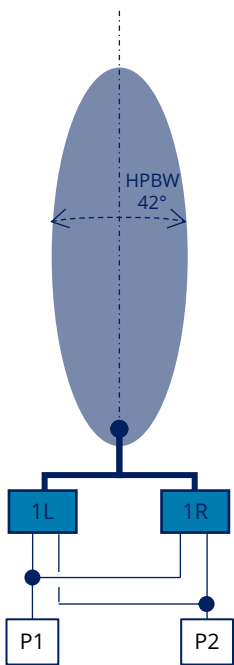

### Beam configuration

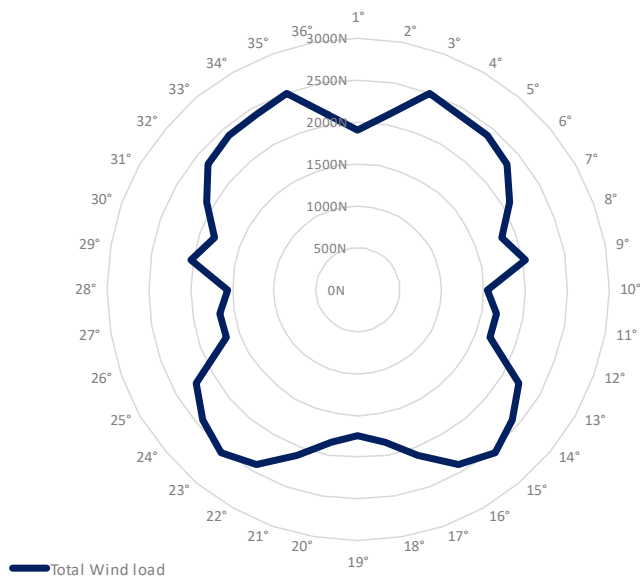

### Windload



## Overview

-  2 Ports / One horizontal lobe
-  Average gain: 28 dBi
-  1710MHz-2170MHz
-  Passive

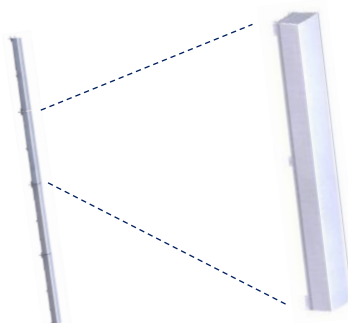
**RI 0302251-04**  
**X 4**

All clusters

Parameter Name	Unit	Value
Frequency Range	MHz	1710-2170
Polarization	°	+45 / -45
Electrical Downtilt	°	0,7
Impedance	Ω	50
Voltage Standing Wave Ratio		< 1,5:1
Passive Intermodulation	dBc	< -153
Return loss	dB	> 14
Inter-cluster Isolation	dB	> 21
Maximum Effective Power Per Port	W	500
Maximum Effective Power Per Cluster	W	2000

Parameter Name	Unit	Value
Cluster Name		1
Nominal Direction	°	0
Nominal Horizontal Half-Power Beamwidth	°	42
Port Number		1 / 2
Intra-cluster Isolation	dB	> 21
Frequency Sub Range	MHz	1710-2170
Gain	dBi	26 → 30
Azimuth Beamwidth	°	42
Elevation Beamwidth	°	0,8
Elevation Downtilt Deviation	dB	< 0,1
First Upper Sidelobe Suppression	dB	> 13
Upper Sidelobe Suppression Peak To 20°	dB	> 13
Upper Sidelobe Suppression Horizon To 20°	dB	> 13
Maximum Upper Sidelobe Suppression	dB	> 13
Null Fill	dB	> -23
Front To Back Ratio Total Power +/-30°	dB	> 25
Efficiency	dB	-0,09
Cross Polar Discrimination at Mechanical Boresight	dB	> 11

## Mechanical Parameters:

Parameter Name	Unit	Value
Connector Type		4.3-10 Female
Location		Back
Mechanical Boresight	°	0
Antenna dimensions H xW x D	mm	9976 x 359 x 270
Packing size H xW x D	mm	5 boxes: 2600 x 390 x 290
Weight without accessories	kg	174
Survival Wind Speed	km/h	250
Windload	N	Frontal: 4034 Lateral: 3545 Maximum 360: 4989
Software simulated results at 150km/h		
Radome Material		PC
Radome Color		RAL7038
Product environmental compliance (general)		ROHS
Product environmental compliance (conditions)		ETSI EN 300019-2-4, Class 4, 1E
Mechanical distance between antenna mounting points	mm	2500
Number of mounting points		5
Lighting protection		Yes

(considering the presence of a surge arrester lightning protection on RRH)

### Port external interface

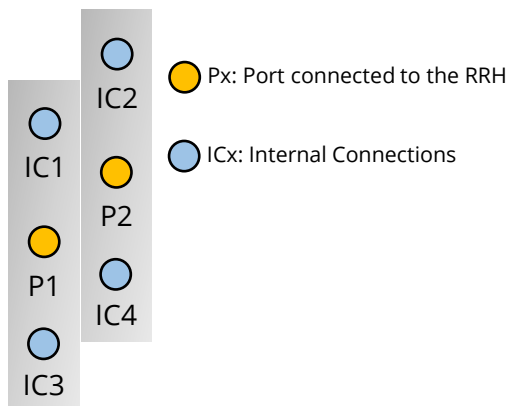

### Mounting

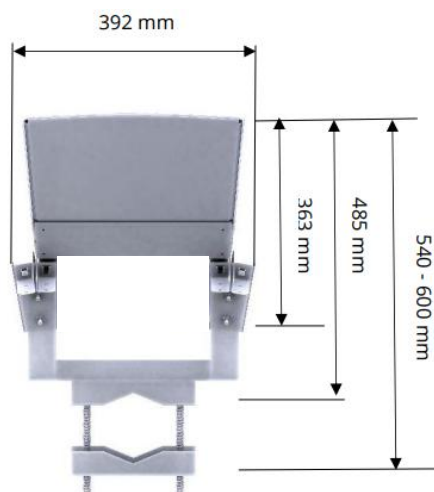

Bracket for tube Ø40-120mm  
Can be adapted upon request



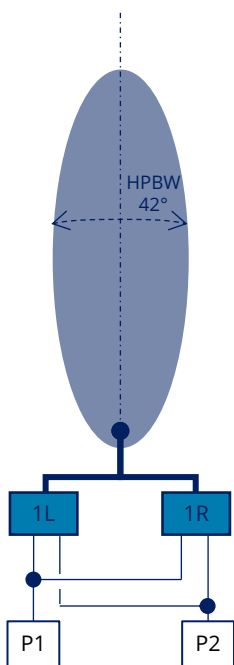

### Beam configuration

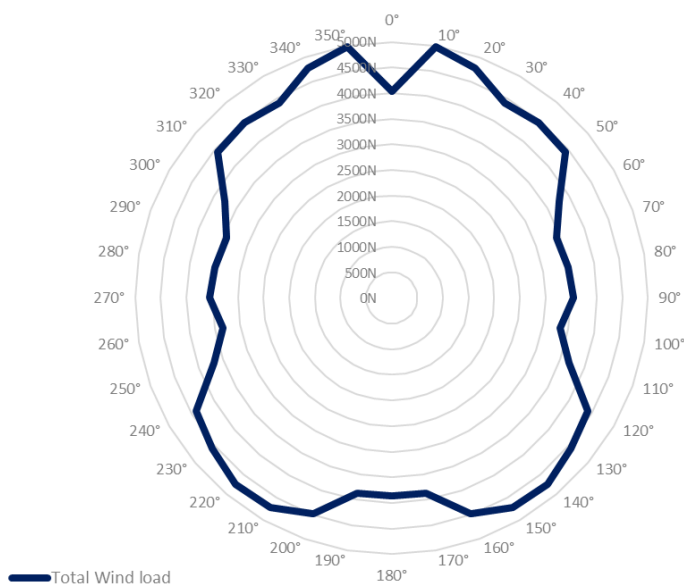

### Windload



## Overview

-  4 Ports / 2 horizontal lobes
-  Average gain: 22 dBi
-  1710MHz-2170MHz
-  Passive



## RF Parameters

### All clusters

Parameter Name	Unit	Value
Frequency Range	MHz	1710-2170
Polarization	°	+45 / -45
Electrical Downtilt	°	0,4
Combined Horizontal Half-Power Beamwidth	°	82
Impedance	Ω	50
Voltage Standing Wave Ratio		< 1,5:1
Passive Intermodulation	dBc	< -153
Return loss	dB	> 14
Inter-cluster Isolation	dB	> 21
Maximum Effective Power Per Port	W	500
Maximum Effective Power Per Cluster	W	2000

### Clusters 1L & 1R

Parameter Name	Unit	Value
Cluster Name		1L 1R
Nominal Direction	°	-20 +20
Nominal Horizontal Half-Power Beamwidth	°	42 42
Port Number		1 / 2 3 / 4
Intra-cluster Isolation	dB	> 21 > 21
Frequency Sub Range	MHz	1710-2170 1710-2170
Gain	dBi	19 → 23 19 → 23
Azimuth Beamwidth	°	44 46
Elevation Beamwidth	°	3,1 3,1
Elevation Downtilt Deviation	dB	< 0,4 < 0,4
First Upper Sidelobe Suppression	dB	> 13 > 13
Upper Sidelobe Suppression Peak To 20°	dB	> 13 > 13
Upper Sidelobe Suppression Horizon To 20°	dB	> 13 > 13
Maximum Upper Sidelobe Suppression	dB	> 13 > 13
Null Fill	dB	> -30 > -30
Front To Back Ratio Total Power +/-30°	dB	> 25 > 25
Efficiency	dB	-0,09 -0,09
Cross Polar Discrimination at Mechanical Boresight	dB	> 11 > 11

## Mechanical Parameters:

Parameter Name	Unit	Value
Connector Type		4.3-10 Female
Location		Back
Mechanical Boresight	°	0
Antenna dimensions H xW x D	mm	2494 x 359 x 270
Packing size H xW x D	mm	2 boxes: 2600 x 390 x 290
Weight without accessories	kg	36,5
Survival Wind Speed	km/h	250
Windload	N	Frontal: 945 Lateral: 572 Maximum 360: 1198
Software simulated results at 150km/h		
Radome Material		PC
Radome Color		RAL7038
Product environmental compliance (general)		ROHS
Product environmental compliance (conditions)		ETSI EN 300019-2-4, Class 4, 1E
Mechanical distance between antenna mounting points	mm	2500
Number of mounting points		2
Lighting protection		Yes

(considering the presence of a surge arrester lightning protection on RRH)

### Port external interface

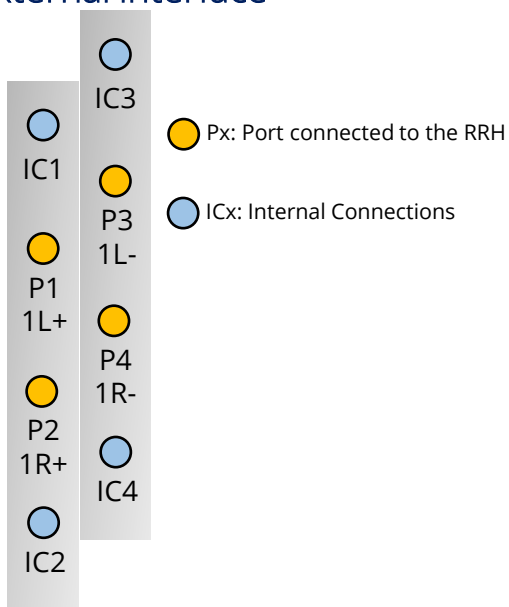

### Mounting

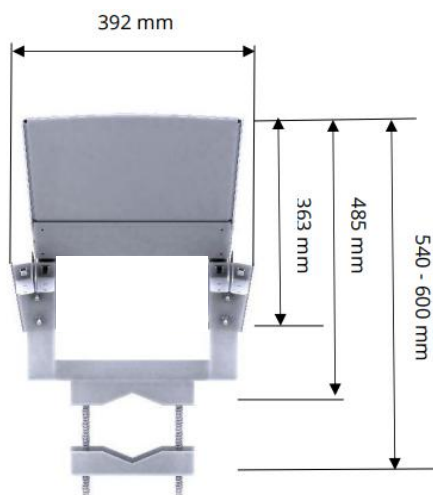

Bracket for tube Ø40-120mm  
Can be adapted upon request

### Beam configuration

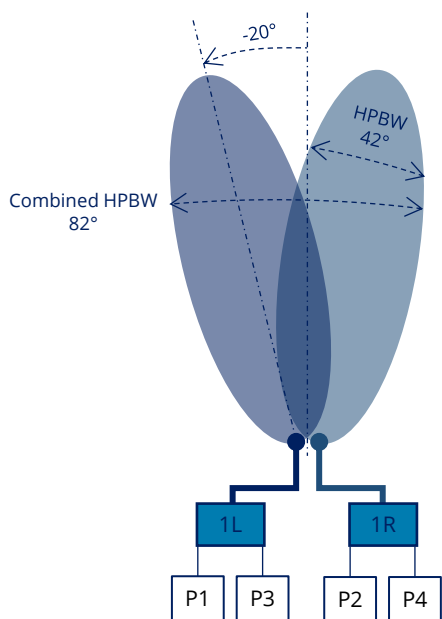



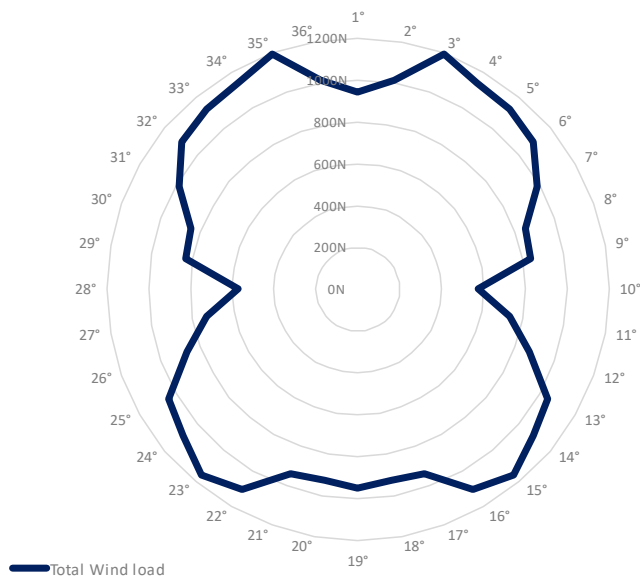

### Windload



**RI 0302252-07**  
 RURAL ANTENNA 2 beams x 42° x 24dBi MB

## Overview

-  4 Ports / 2 horizontal lobes
-  Average gain: 24 dBi
-  1710MHz-2170MHz
-  Passive

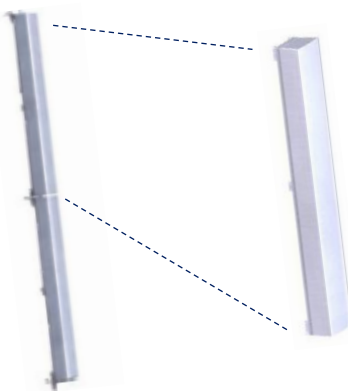
**RI 0302251-04**  
**X 2**

All clusters

Parameter Name	Unit	Value
Frequency Range	MHz	1710-2170
Polarization	°	+45 / -45
Electrical Downtilt	°	0,7
Combined Horizontal Half-Power Beamwidth	°	82
Impedance	Ω	50
Voltage Standing Wave Ratio		< 1,5:1
Passive Intermodulation	dBc	< -153
Return loss	dB	> 14
Inter-cluster Isolation	dB	> 21
Maximum Effective Power Per Port	W	500
Maximum Effective Power Per Cluster	W	2000

Clusters 1L &amp; 1R

Parameter Name	Unit	Value
Cluster Name		1L 1R
Nominal Direction	°	-20 +20
Nominal Horizontal Half-Power Beamwidth	°	42 42
Port Number		1 / 2 3 / 4
Intra-cluster Isolation	dB	> 20,6 > 20,6
Frequency Sub Range	MHz	1710-2170 1710-2170
Gain	dBi	22 → 26 22 → 26
Azimuth Beamwidth	°	44 46
Elevation Beamwidth	°	1,6 1,6
Elevation Downtilt Deviation	dB	< 0,1 < 0,1
First Upper Sidelobe Suppression	dB	> 11 > 11
Upper Sidelobe Suppression Peak To 20°	dB	> 11 > 11
Upper Sidelobe Suppression Horizon To 20°	dB	> 11 > 11
Maximum Upper Sidelobe Suppression	dB	> 11 > 11
Null Fill	dB	> -16 > -14
Front To Back Ratio Total Power +/-30°	dB	> 25 > 25
Efficiency	dB	-0,09 -0,09
Cross Polar Discrimination at Mechanical Boresight	dB	> 11 > 11

## Mechanical Parameters:

Parameter Name	Unit	Value
Connector Type		4.3-10 Female
Location		Back
Mechanical Boresight	°	0
Antenna dimensions H xW x D	mm	4988 x 359 x 270
Packing size H xW x D	mm	3 boxes: 2600 x 390 x 290
Weight without accessories	kg	91
Survival Wind Speed	km/h	250
Windload	N	Frontal: 1906 Lateral: 1550 Maximum 360: 2541
Software simulated results at 150km/h		
Radome Material		PC
Radome Color		RAL7038
Product environmental compliance (general)		ROHS
Product environmental compliance (conditions)		ETSI EN 300019-2-4, Class 4, 1E
Mechanical distance between antenna mounting points	mm	2500
Number of mounting points		3
Lighting protection		Yes

(considering the presence of a surge arrester lightning protection on RRH)

### Port external interface

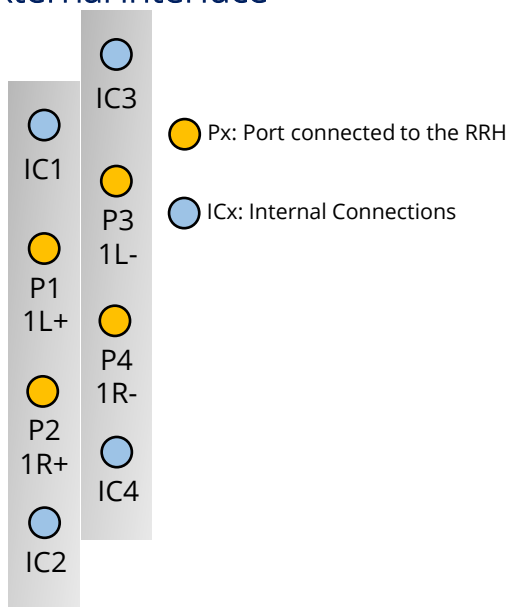

### Mounting

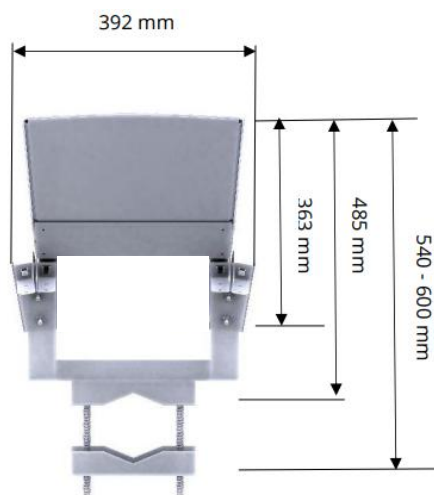

Bracket for tube Ø40-120mm  
Can be adapted upon request



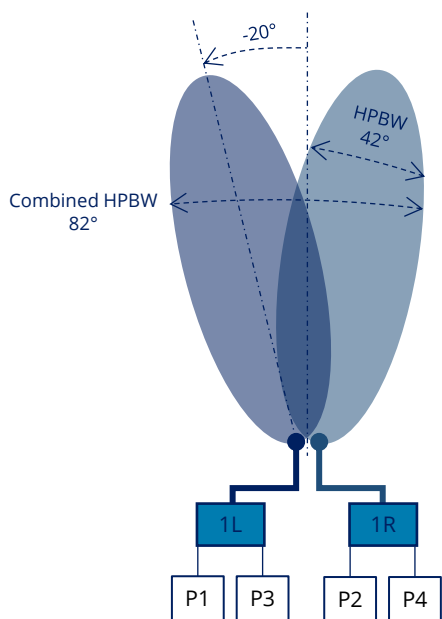

### Beam configuration

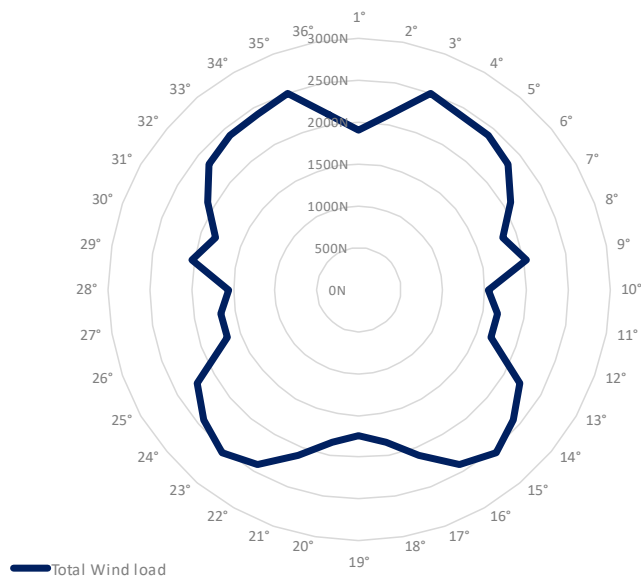

### Windload



## Overview

-  4 Ports / 2 horizontal lobes
-  Average gain: 27 dBi
-  1710MHz-2170MHz
-  Passive

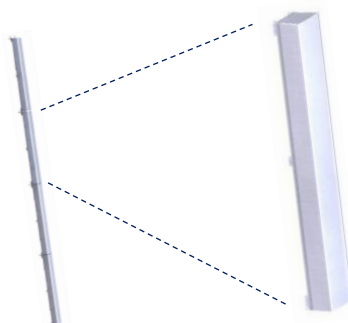
 RI 0302251-04  
**X4**

## RF Parameters

### All clusters

Parameter Name	Unit	Value
Frequency Range	MHz	1710-2170
Polarization	°	+45 / -45
Electrical Downtilt	°	0,7
Combined Horizontal Half-Power Beamwidth	°	82
Impedance	Ω	50
Voltage Standing Wave Ratio		< 1,5:1
Passive Intermodulation	dBc	< -153
Return loss	dB	> 14
Inter-cluster Isolation	dB	> 21
Maximum Effective Power Per Port	W	500
Maximum Effective Power Per Cluster	W	2000

### Clusters 1L & 1R

Parameter Name	Unit	Value
Cluster Name		1L 1R
Nominal Direction	°	-20 +20
Nominal Horizontal Half-Power Beamwidth	°	42 42
Port Number		1 / 2 3 / 4
Intra-cluster Isolation	dB	> 21 > 21
Frequency Sub Range	MHz	1710-2170 1710-2170
Gain	dBi	26 → 29 26 → 29
Azimuth Beamwidth	°	44 46
Elevation Beamwidth	°	0,8 0,8
Elevation Downtilt Deviation	dB	< 0,1 < 0,1
First Upper Sidelobe Suppression	dB	> 13 > 13
Upper Sidelobe Suppression Peak To 20°	dB	> 13 > 13
Upper Sidelobe Suppression Horizon To 20°	dB	> 13 > 13
Maximum Upper Sidelobe Suppression	dB	> 13 > 13
Null Fill	dB	> -21 > -11
Front To Back Ratio Total Power +/-30°	dB	> 25 > 25
Efficiency	dB	-0,09 -0,09
Cross Polar Discrimination at Mechanical Boresight	dB	> 11 > 11

## Mechanical Parameters:

Parameter Name	Unit	Value
Connector Type		4.3-10 Female
Location		Back
Mechanical Boresight	°	0
Antenna dimensions H xW x D	mm	9976 x 359 x 270
Packing size H xW x D	mm	5 boxes: 2600 x 390 x 290
Weight without accessories	kg	174
Survival Wind Speed	km/h	250
Windload	N	Frontal: 4034 Lateral: 3545 Maximum 360: 4989
Software simulated results at 150km/h		
Radome Material		PC
Radome Color		RAL7038
Product environmental compliance (general)		ROHS
Product environmental compliance (conditions)		ETSI EN 300019-2-4, Class 4, 1E
Mechanical distance between antenna mounting points	mm	2500
Number of mounting points		5
Lighting protection		Yes

(considering the presence of a surge arrester lightning protection on RRH)

### Port external interface

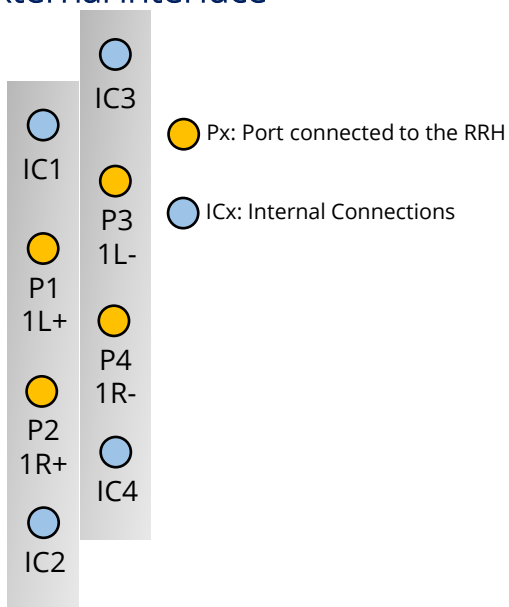

### Mounting

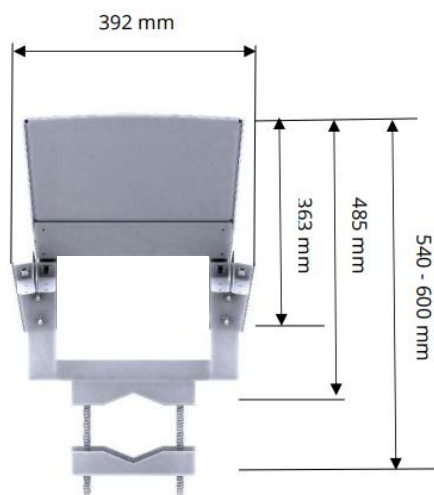

Bracket for tube Ø40-120mm  
Can be adapted upon request

### Beam configuration

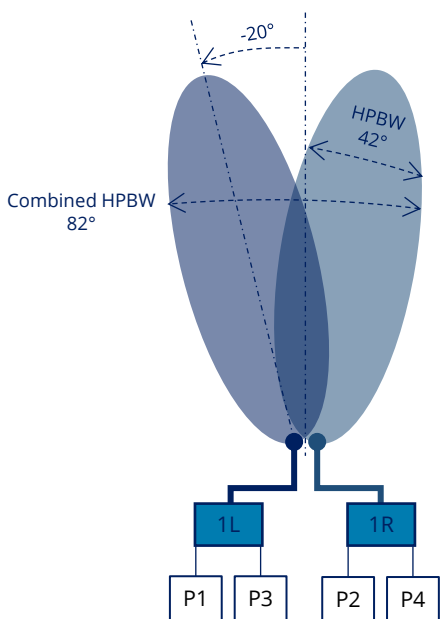

### Windload

